

# PRODUCT DATA

VPL 15 TOP M2 BY NILAN



## Ventilation & active heat recovery



Domestic



Active  
heat recovery



Ventilation  
< 400 m<sup>3</sup>/h



Comfort  
heating



Comfort  
cooling

# VPL 15 TOP M2

## Product description

VPL 15 Top M2 is an energy-efficient ventilation unit for heat recovery and cooling of homes and small commercial buildings with a ventilation requirement of up to 400 m<sup>3</sup>/h.

Heat recovery is via a heat pump that can utilise the recovered energy better than with e.g. a counterflow heat exchanger.

The heat pump has a reversible cooling circuit, which means that the unit can both heat and cool the air.

VPL 15 Top M2 is a system with compact dimensions.

VPL 15 Top M2 is supplied fully tested and ready for use. Fitting and commissioning must be carried out by an authorised electrician or plumber.



VPL 15 Top M2 is supplied with a closed cooling circuit.

The unit can therefore be installed without the help of a cooling technician.



The efficient fans run on low-energy EC motors.



The cooling circuit is driven by a reliable reciprocating compressor.



Intelligent humidity sensors provide an option for controlling the ventilation as required, based on the average air humidity in the home.

A CO<sub>2</sub> sensor can be purchased as an accessory.



Reversible cooling circuit, which means that the heat pump can heat and cool the supply air.



The powder-coated condensate drain prevents the formation of "acid water" and allows the condensate to be drained away.



The option of the FU 15 heat pipe unit with heat pipe will significantly increase the unit efficiency. This can maintain a high intake air temperature without using a heating coil.



Time-controlled alarm for filter exchange.

As standard ISO Coarse >90% (G4) filters are provided in extract air and the outdoor air intake. Filters are replaced easily by opening the top door by using two finger screws.



The alternative to an FU 15 heat pipe unit is the installation of an external water heater or electrical heating element (accessory).



The unit comes with a clear and user-friendly touch panel. The modern CTS 602 HMI touch panel runs Modbus communication.

## Technical specifications

Dimensions (W x D x H)	600 x 600 x 710 mm
Weight	64 kg
Plate type casing	Aluzinc steel plate, white powder coating RAL9016
Heat loss casing (*1)	32 W / -32 W
Compressor type	Piston compressor
Refrigerant	R134a
Fan type	EC, constant volume
Filter class	Standard ISO Coarse >90% (G4)
Duct connections	Ø160 mm
Condensate drain	PVC, Ø20x1,5 mm

Supply voltage	230 V (±10 %), 50/60 HZ
Max. input/power	720W / 4.3A
Tightness class	IP31
Standby power	3W
Ambient temperature	-20 / +40 °C

\*1 32 W: Outdoor air temperature -12 °C. Fitting location -12 °C. Extract air temperature 20 °C (room).  
 -32 W: Outdoor air temperature -12 °C. Fitting location 20 °C. Extract air temperature 20 °C (room).

## Dimensional drawing

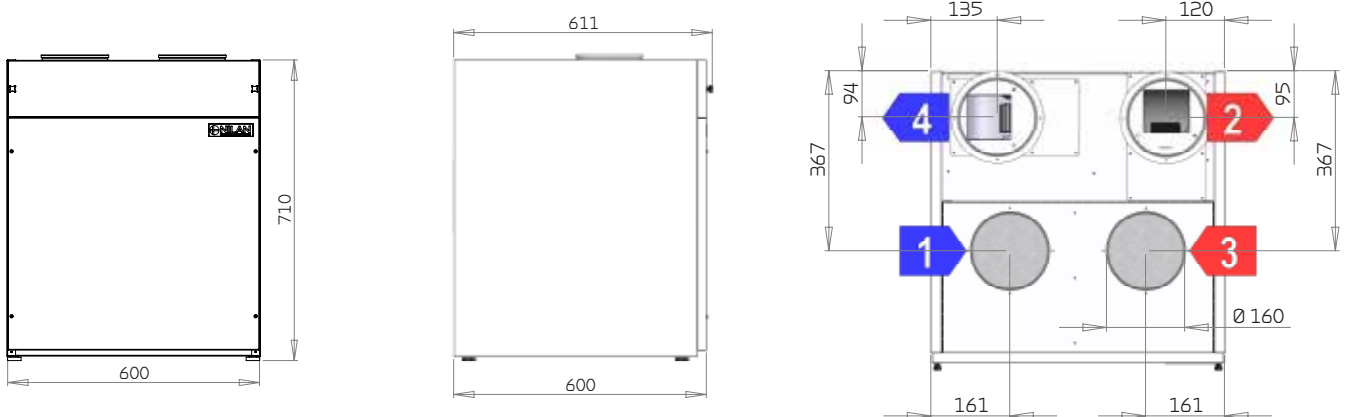

All dimensions are in mm.

### Connections

- 1: Fresh air
- 2: Supply air
- 3: Extract air
- 4: Discharge air

# FU15

## Product description

An option is a FU 15 heat pipe unit with filter, which is connected to the VPL 15 Top M2 unit.

The heat pipe slightly raises the temperature of the outdoor air, thereby increasing the heat pump's efficiency in the VPL 15 Top M2 unit significantly during the winter.

With an integrated FU 15 heat pipe unit, in most cases there is no need for a heating coil with mixing circuit.



## Dimensional drawing

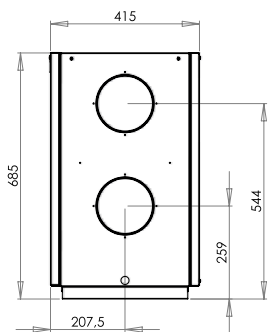

All dimensions are in mm.

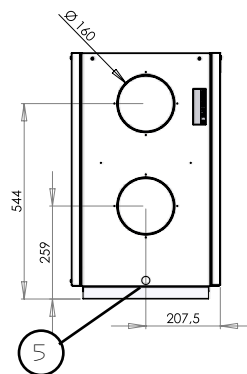
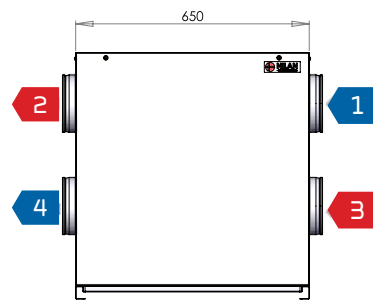

### Connections

- 1: Fresh air
- 2: Supply air
- 3: Extract air
- 4: Discharge air
- 5: Condensate drain

## Scan the QR code

Scan the QR code with your smartphone or tablet and view a brief film on:

- How the VPL aggregates function
- How efficient heat recovery is
- How the cooling functions



## Intelligent humidity control

Nilan's humidity control automatically adapts to the needs of the family or the building.

The intelligent CTS 602 control unit does not need to have a set level input for air humidity (RH) to control the air exchange. By using the integrated humidity sensor, the control unit calculates the average level itself for the last 24 hours. The average level provides a basis for deciding whether to change the air exchange if the air humidity fluctuates.

This ensures that the unit always runs at its most efficient, based on the actual air humidity level and not on a theoretical one.

This helps save energy because it automatically adapts to the requirements in the home. Whether a large family or a single person is living in the building has a considerable influence on how much humidity is produced.

The unit also adjusts automatically to summer and winter level.

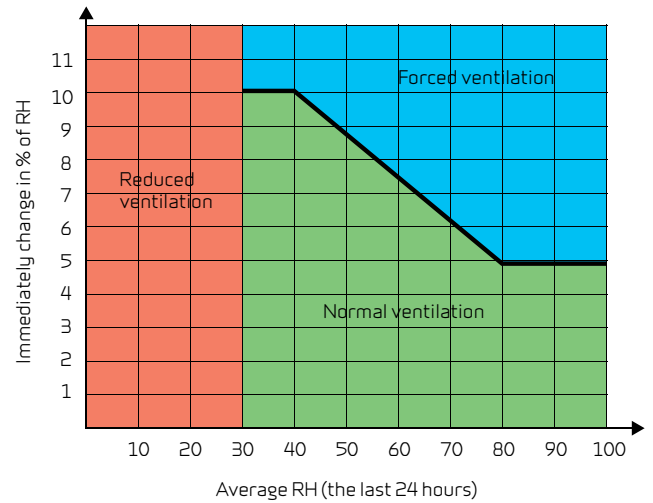

If the air humidity changes by more than 5-10% in relation to the average level, the unit responds with a higher rate of air exchange accordingly.

At an air humidity below 30% is reduced ventilation step activated (adjustable between 15 and 45%)

## Functional diagrams

Heating

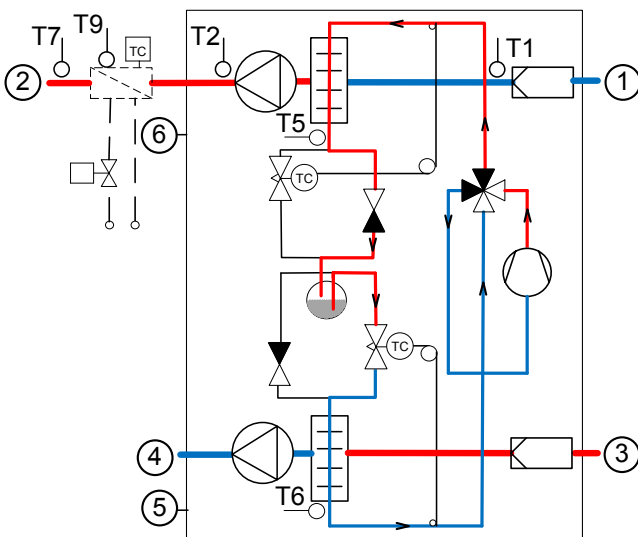

Cooling

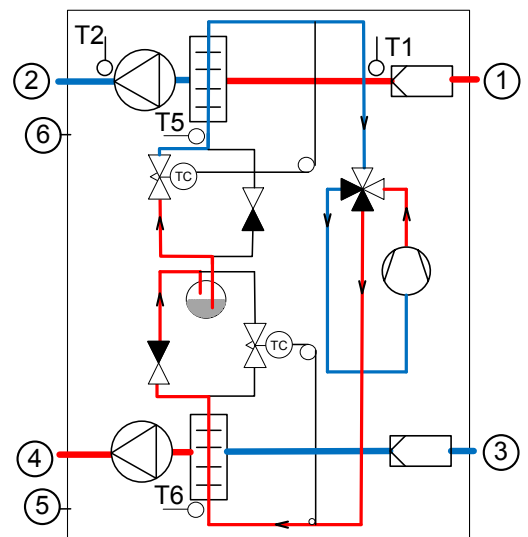

### Connections

- 1: Fresh air
- 2: Supply air
- 3: Extract air
- 4: Discharge air
- 5: Condensate drain
- 6: Electric and water heating

### Automatik

- T1: Outdoor air sensor
- T2/T7: Supply air sensor
- T9: Heating element frost protection
- T5: Capacitor sensor
- T6: Evaporator sensor
- T10: Room sensor

# PLANNING DATA

## Capacity

Max Pa capacity of standard unit,  $P_{t,ext}$  as a function of  $q_v$ , with regard to SEL-values.

SEL-values according to EN13414-7 for a standard unit with ISO Coarse >90% (G4) filters and no heating element.

SEL values comprise the unit's total power consumption incl. control.

**Attention! The SEL values are measured and stated as a total value for both fans.**

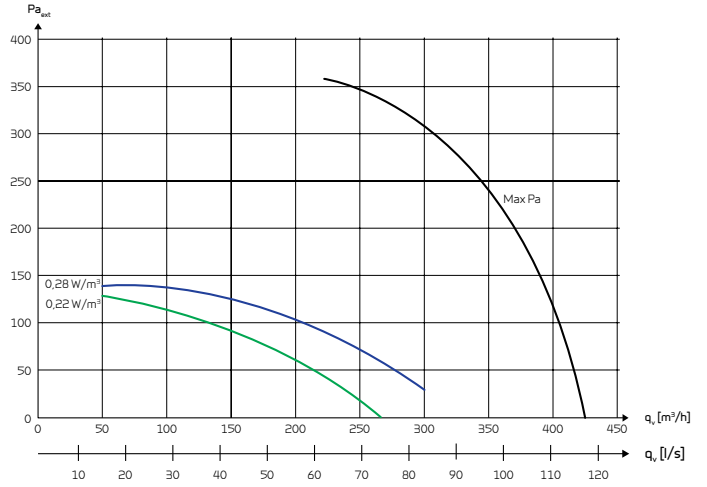

## COP (heating)

Heat effect factor COP [-] supply air as function of outdoor temperature [ $^{\circ}C$ ] and volume flow  $q_v$  [ $m^3/h$ ].

According to EN14511, extract air =  $21^{\circ}C$ .

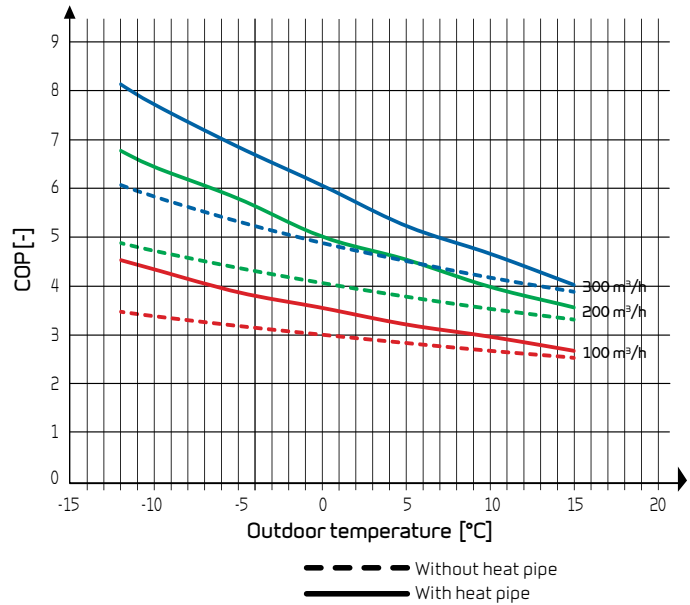

## Heat effect (supply air)

Heat effect  $Q_c$  [W] as a function of  $q_v$  [ $m^3/h$ ] and fresh air temperature [ $^{\circ}C$ ].

According to EN 14511, extract air =  $21^{\circ}C$

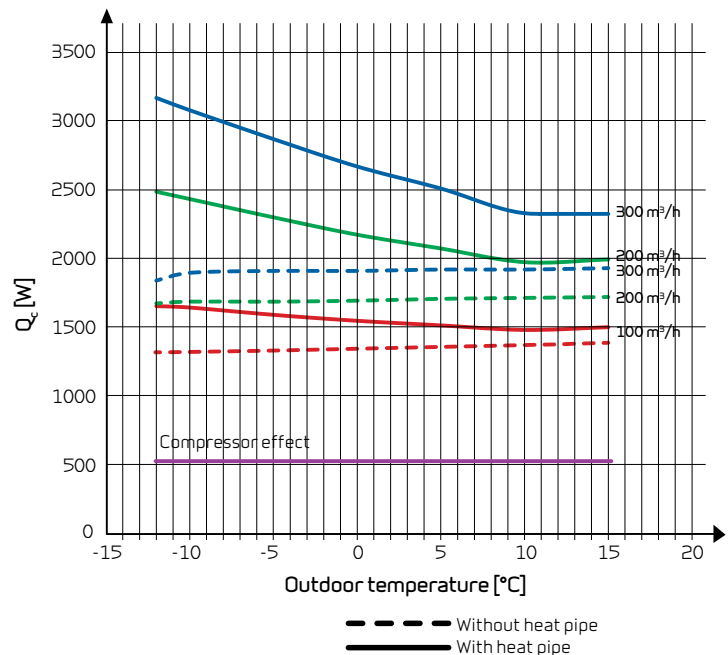

## Supply air temperature (heating)

Supply air temperature [°C] as a function of fresh air temperature [°C] and volume flow  $q_v$  [m<sup>3</sup>/h] balanced flow.

Extract air temperature = 21 [°C], 45 RH [%]

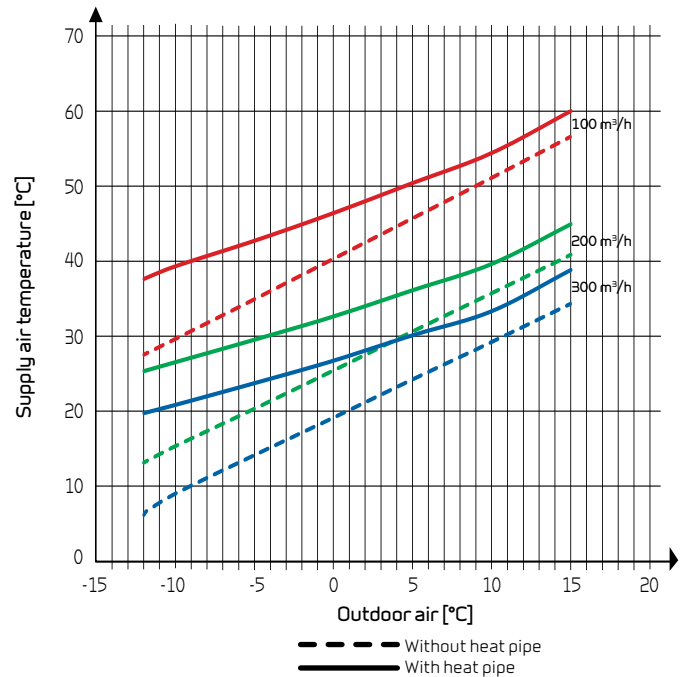

## Supply air temperature (cooling)

Supply air temperature [°C] as a function of fresh air temperature [°C] and volume flow  $q_v$  [m<sup>3</sup>/h] balanced flow.

Extract air temperature = 24°C

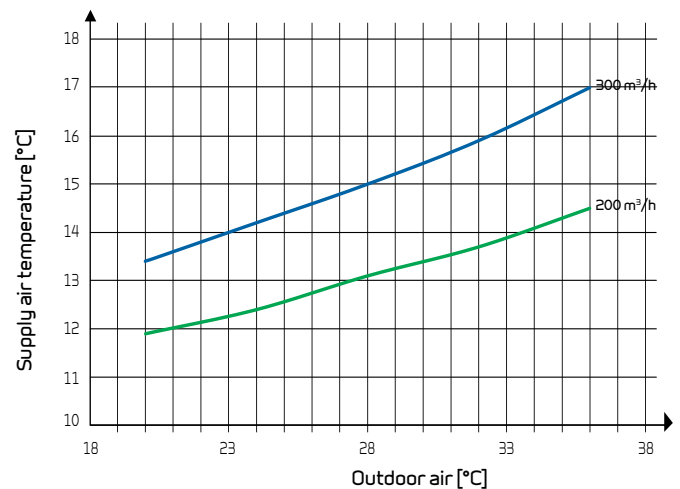

## Sound data

Sound data for  $q_v = 210$  m<sup>3</sup>/h and  $P_{t, ext} = 100$  Pa according to EN 9614-2 for surfaces and EN 5136 for ducts.

Sound output level  $L_{WA}$  drops with falling air volume and falling back pressure.

Sound output level  $L_{pA}$  at a given distance will depend on acoustic conditions in the place of installation.

### Sound output level ( $L_{WA}$ )

Octave band Hz	Surface dB(A)	Supply air dB(A)	Extract air dB(A)
63	-	51	38
125	-	59	46
250	-	66	51
500	-	61	41
1.000	-	56	31
2.000	-	54	28
4.000	-	47	20
8.000	-	40	13
Total ±2	57	69	53

# AUTOMATION

## CTS602 Control



The CTS602 HMI touch panel is featuring a wide range of functions, e.g., menu-controlled operation, weekly programme settings, filter monitor with timer, fan speed adjustment, summer bypass (free cooling), supply-heating element control, error messages etc.

The CTS602 comes with factory settings, including a default setting which can be customised to operational requirements to achieve optimum operation and utilisation of the system.

There is an option for selecting between 2 front page images for the main screen.

Operating instructions for the CTS 602 can be found in a separate user manual supplied with the unit.

## Nilan User APP

By purchasing a Nilan gateway, the user can gain access to the unit via a Nilan User APP. The APP enables the user to access and monitor the current operation, also from the outside of the property.

The APP allows you to adjust the default settings of, for instance, room temperature, fan speed level and the humidity control system.

The APP shows when filter change is next due. This is an important function, and you are automatically notified when filters need changing or an alarm is triggered.

It also provides you with useful trend curves so you can follow the operation of the unit for the previous week with regards to, for instance, room temperature or humidity level.

Using a LAN connector, you connect the gateway to the Modbus of the unit and then to the user's internet router via a LAN or a WiFi connection. This creates a secure cloud connection between the unit and the smartphone.



## External communication

The CTS602 control unit communicates by default with Modbus RTU RS485 communication. A CTS system using this form of communication can easily be connected to the unit.

Nilan units have an open Modbus communication, i.e. not only can the unit be monitored, but its operation can also be set in the same way as it can via the operating panel.

The protocol is by default set up for a Modbus RTU30 address; however, values can be set between 1 and 247.

A Modbus converter allows you to connect one or more units to a computer to monitor and control the unit.

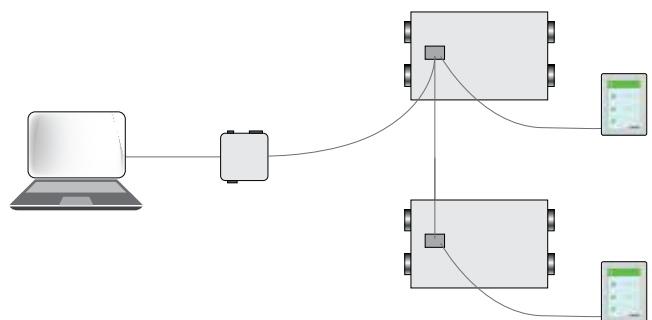



Functions overview		+ Standard - Accessories
Alarms	Description of errors indicated with alarms. Alarm log displaying the latest 16 alarms.	+
Joint alarm	The CTS602 control system has an output signal that is activated in the case of an alarm. It can be connected to, for example, external automation.	
Filter monitor	Filter alarm with timer that can be set to 30/90/180/360 days.	+
Data display	An overview of the current operation with regards to temperatures, fan speed level etc.	+
Week program	The CTS602 control system has 3 week programs that can be set individually (the default setting is "off").	+
Humidity control system	Enables a higher or lower degree of ventilation at a high/low level of humidity.	+
Air quality	Enables you to adjust the degree of ventilation depending on the CO <sub>2</sub> level in the air.	-
Winter low	You can prevent a low level of humidity in the dwelling by activating low ventilation at low outdoor temperatures.	+
Temperature regulation	Enables you to control the operation of the unit in accordance with the room temperature.	+
Summer/winter mode	You can set the unit to operate in summer or winter mode.	
Language	You can choose from more than 10 languages in the control panel.	+
User levels	The menu in the control panel is divided into 3 user levels: User/Installer/Factory.	+
User selection 1	Enables you to override the operating mode via an external potential free signal.	+
User selection 2	Enables you to override the operating mode as well as user selection 1 via an external potential free signal.	-
Air exchange	Stepless setting of four fan speed levels. The supply air and the extract air can be set individually.	+
De-icing	Based on temperature, this automatic function de-ices the counterflow heat exchanger if ice has formed within it.	+
Room low	Safety function that will cause the ventilation unit to stop if the heating system for the dwelling fails. This will prevent the unit from cooling the dwelling even further.	+
External heating	The ventilation unit can control an external heat supply in accordance with the current room temperature.	+
External fire automation system	You can connect the ventilation unit to an external fire automation system or to a fire thermostat. This will signal to the unit whether to stop or continue operation.	+
Pressure sustaining regulator	You can install a pressure sustaining regulator on the side of both the extract air and the supply air.	-
Delayed start-up	You can activate a delayed start-up of the fans if you install, for instance, a shut-off damper.	+
Restore settings	You can save the current settings and subsequently restore them if, for instance, the user has altered the settings on the unit. You can also reinstall the default settings.	+
Manual operation	Different functions can be tested manually.	+
Energy saving function	You can activate a power saving function of the operation.	+
Modbus	You can set the Modbus address of the unit. The default setting is 30.	+
Data logging	It is possible to log the operational data of the unit every 1 - 120 min. Alarms are logged when they occur.	+
Control panel	You can choose from 2 different images for the main screen.	+

You can find further information about all the functions in the Software and Installation instructions for the unit.

# ACCESSORIES



## CO<sub>2</sub>-sensor

With a CO<sub>2</sub>-sensor installed, the ventilation speed can be pre-programmed with CTS 602 to run at a higher ventilation steps when CO<sub>2</sub> reaches high level in the extract air. CO<sub>2</sub>-level is programmable.



## Water heating element incl. regulation

The supply temperature can always be raised to the required level using a water heating element. The water heating element is designed to be built into the duct and must be connected to the primary heating supply. Supplied with two-way adjustment valve, temperature sensor and frost thermostat.



## Electrical heating element incl. regulation

When you fit an electrical heating element, you can raise the fresh air temperature to the desired level at any time. The electrical heating element is supplied ready to fit into the fresh air duct and, for easy fitting, the device is pre-fitted with all the required sensors.



## EM-box

An EM-box allows heat recovery from the air from the range hood and thereby helps to heat the supply air. The EM-box is equipped with a special filter which efficiently cleans the range hood air of fat particles and thereby protects the system.



## Expansion PCB

The expansion PCB provides additional functions for the CTS 602 control unit, e.g., controlling the EM box (see list of functions on page 9).



## Installation kit

The installation kit comprises of four vibration absorbers and a water trap for the condensation outlet. The water trap can be ordered separately.



## Heating cable

To protect the condensation outlet against frost, a 3 or 5 metre-long self-regulating heating cable can be ordered.

# DELIVERY AND HANDLING

## Transport and storage

VPL 15 Top M2 comes in factory packaging that protects it during transport and storage.

VPL 15 Top M2 must be stored in a dry place in its original packaging until installation.

The packaging should only be removed immediately prior to installation.

## Installation conditions

When installing, plan ahead for service and maintenance. We recommend minimum clearance in front of the unit of 60 cm.

Ensure the unit is level, with regard to the condensation drain. The condensation drain requires clearance of min. 20 cm under the drain spout.

Use a flexible connection between the unit's nozzle and duct system.

The unit is quiet and low vibration, but the fact that vibrations can still be transmitted to the building fabric should be taken into account. We recommend a minimum distance of 30 mm to the building fabric and other fixtures. We recommend erecting the unit on vibration dampers to separate it from the surface it stands on.

VPL 15 Top M2

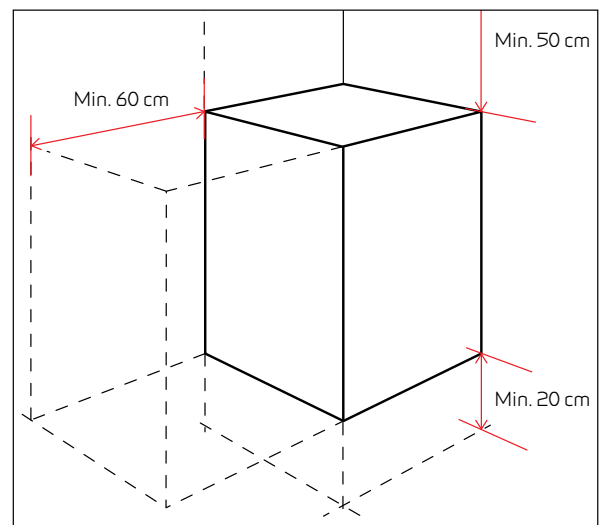

## Installation of electric heating element

Electric heating elements (accessories) are fitted in the duct. The heating element must be insulated using fire-resistant insulation material.

The electric heating element must be connected by an authorised electrician.

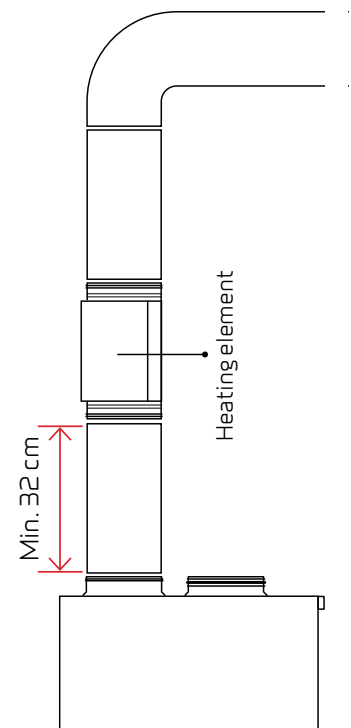

# INFORMATION FROM A TO Z

Nilan develops and manufactures premium-quality, energy-saving ventilation and heat pump solutions that provide a healthy indoor climate and low-level energy consumption with the greatest consideration for the environment. In order to facilitate each step in the construction process - from choosing the solution through to planning, installation and maintenance - we have created a series of information material which is available for download at [www.nilan.dk](http://www.nilan.dk).



## Brochure

General information about the solution and its benefits.



## Product data

Technical information to ensure correct choice of solution.



## Installation instructions

Detailed guide for installation and initial adjustment of the solution.



## User manual

Detailed guide for regulation of the solution to ensure optimum day-to-day operation.

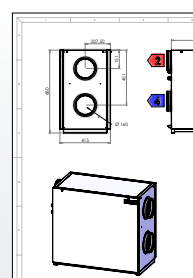

## Drawings

Tender documents and 3D drawings are available to download for planning purposes.

[WWW.NILAN.DK](http://WWW.NILAN.DK)

Visit us at [www.nilan.dk](http://www.nilan.dk) to find out more about our company and solutions, download further information and find your nearest dealer.



Nilan A/S  
Nilanvej 2  
8722 Hedensted  
Denmark  
Tel. +45 76 75 25 00  
Fax +45 76 75 25 25  
[nilan@nilan.dk](mailto:nilan@nilan.dk)  
[www.nilan.dk](http://www.nilan.dk)